

**Compensation of
harmonic currents
generated by
computers utilizing
an innovative active
harmonic
conditioner**

THE MERLIN GERIN KNOW-HOW

M G E
UPS SYSTEMS

Nothing will stop you now

Compensation of harmonic currents generated by computers utilizing an innovative active harmonic conditioner

Authors: Serge BERNARD Gérard TROCHAIN

Contents

1. abstract	3
2. introduction	4
3. traditional solutions in eliminating harmonic currents	5
■ oversizing or derating of the installation	5
■ specially connected transformers	5
■ series reactors	5
■ tuned passive filter	5
4. topologies of active harmonic conditioners	6
■ series conditioners	6
■ parallel conditioners	6
■ hybrid conditioners	7
5. parallel active conditioner: system description	8
■ operating principle	8
■ recording of real current for non-linear load	8
■ detailed description	9
■ points of connection of the active conditioner	10
6. case study: Elf Aquitaine	11
■ description of the installation	11
■ problems experienced by Elf and site audit.....	12
■ analyse of the solutions	13
■ final solution.....	13
■ site results	14
7. comparison between active harmonic conditioner and tuned passive filter	17
8. conclusion	18
annex 1	19
■ references	19

abstract

In little more than ten years, electricity power quality has grown from obscurity to a major issue.

Electronic converters and power electronics gave birth to numerous new applications, offering unmatched comfort, flexibility and efficiency to the customers. However, their proliferation during the last decade is creating a growing concern and generates more and more problems: not only these electronic loads pollute the AC distribution system with harmonic currents, but they also appear to be very sensitive to the voltage distortion.

Then, electricity power quality is becoming a major issue for utilities and for their customers, and both are quickly adopting the philosophy and the limits proposed by the new International Standards (519-1992 IEEE, 61000.3-2/4 IEC).

Today, recent advances in power electronic technology are providing an unprecedented capability for conditioning and compensating harmonic distortion generated by the non-linear loads.

The case study presented in this paper demonstrates the role of the power source, the load and the AC distribution system as regards power quality. The benefit of harmonic cancellation equipment is clearly shown. Among the different technical solutions, a shunt - current injection mode - active harmonic conditioner is evaluated, and detailed site measurements are presented as confirmation of the unsurpassed performances.

This new innovative active conditioner appears to be the easiest of use, the most flexible, the most efficient and cost effective one.

2. introduction

Today, the situation on low-voltage AC systems has become a serious concern. The quality of electrical power in commercial and industrial installations is undeniably decreasing.

In addition to external disturbances, such as outages, sags and spikes due to switching and atmospheric phenomena, there are inherent, internal causes specific to each site and resulting from the combined use of linear and non-linear loads.

Untimely tripping of protection devices, harmonic overloads, high levels of voltage and current distortion, temperature rise in conductors and generators all contribute to reducing the quality and the reliability of a low-voltage AC system.

The above disturbances are well understood and directly related to the proliferation of loads consuming non-sinusoidal current, referred to as "non-linear loads". This type of load is used for the conversion, variation and regulation of electrical power in commercial, industrial and residential installations.

The prospect of a rapid return to linear-load conditions is illusory. Recent studies show that the consumption of non-linear current will sharply increase in the years to come.

However, the remarkable progress made by power electronic devices in the recent years, fast IGBT's, makes it possible to design self adaptable harmonic suppressors called **active harmonic conditioner**, known also as active filters. Active harmonic conditioners are proving to be viable option for controlling harmonic distortion levels in many applications.

3. traditional solutions in eliminating harmonic currents

Today, a various panel of harmonic mitigation equipment or solutions is proposed, but all present some disadvantages. These solutions are listed here after.

oversizing or derating of the installation

This solution does not attempt to eliminate the harmonic currents flowing in the electrical installation, but rather to "make do" by avoiding the consequences.

When designing a new installation, the idea is to oversize all installation elements likely to transmit harmonic currents, namely the transformers, cables, circuit-breakers, engine generator sets and the distribution switchboards. The most widely implemented solution is oversizing of the neutral conductor.

The result is a **major increase in cost**.

In existing installations, the most common solution is to derate the electrical distribution equipment subjected to the harmonic currents. The consequence is an installation that cannot be used to its full potential.

specially connected transformers

This solution inhibits propagation of third-order harmonic currents and their multiples. It is a centralized solution for a set of single phase loads.

However, it produces no effect on harmonic orders that are not multiples of three (H5, H7, ...). On the contrary, this solution limits the available power from the source and increases line impedance. The consequence is an increase in the voltage distortion due to the other harmonic orders.

series reactors

This solution, used for variable speed drives and three phase rectifiers, consists in connecting a reactor in series upstream of a non-linear-load. A reactor is not expensive, but has limited effectiveness. One must be installed for each non-linear load. Current distortion is divided by a factor of approximately two.

tuned passive filter

The idea is to "trap" the harmonic currents in L/C circuits tuned to the harmonic orders requiring filtering. A filter therefore comprises a series of "stages", each corresponding to an harmonic order. Orders 5 and 7 are the most commonly filtered.

A filter may be installed for one load or a set of loads. Its design requires in-depth study of the AC system and collaboration with a consulting engineer. Sizing depends on the harmonic spectrum of the load and the impedance of the power source. Rating also must be co-ordinated with reactive power requirements of the loads, and it is often difficult to design the filters to avoid leading power factor operation for some load conditions.

This solution is moderately effective and its design depends entirely on the given power source and the loads, i.e. it is not flexible and is virtually impossible to upgrade. Its application may create system resonance which are dependent on specific system conditions.

Note: when appropriately designed, this type of filter may also be used to eliminate harmonic distortion already present on the electrical network of the power distributor, provided a significant overrating for harmonic absorption from the power system.

4. topologies of active harmonic conditioners

The idea of **active harmonic conditioners**, also named active filters, is relatively old, however the lack of an effective technique at a competitive price slowed its development for a number of years.

Today, the wide-spread use of IGBT components, mastery of their implementation and the availability of new digital signal processing (DSP) techniques are paving the way to a much brighter future for the active harmonic conditioner.

The active harmonic conditioner concept uses power electronics to produce harmonic components which cancel the harmonic components of the non-linear loads. A number of different topologies are being proposed, whom some of them are described here after. Within each topologies there are issues of required components ratings and method of rating the overall conditioner for the loads to be compensated.

series conditioners

This type of conditioner, connected in series on the distribution network, compensates both the harmonic currents generated by the load and the voltage distortion already present on the AC system. This solution is technically similar to a line conditioners and must be sized for the total load rating.

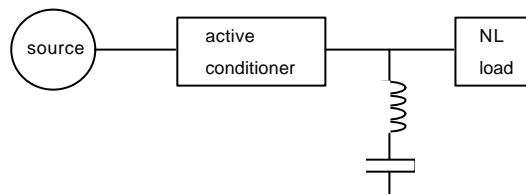

Fig. 01

parallel conditioners

Also called shunt conditioners they are connected in parallel with the AC line and need to be sized only for the harmonic power (harmonic current) drawn by the non-linear load(s). The parallel topology selected for SineWave is in no way dependent on the load or electrical AC system characteristics. It is described in detail in the section 4.

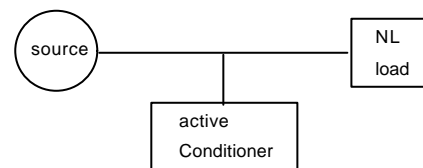

Fig. 02

4. topologies of active harmonic conditioners

hybrid conditioners

This solution, combining an active conditioner and a passive filter, may be either of the series or parallel type. In certain cases, it may be a cost-effective solution. The passive filter carries out basic filtering (5th order, for example) and the active conditioner, through its precise and dynamic technique, covers the other orders.

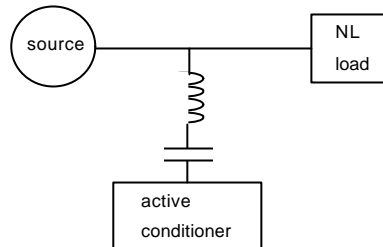
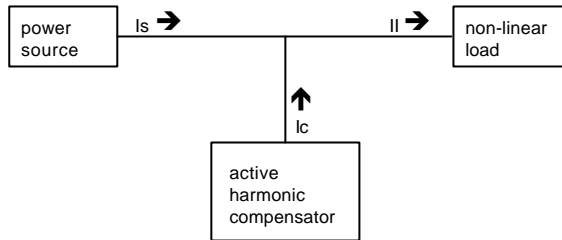

Fig. 03

5. parallel active harmonic conditioner: system description

operating principle

The active conditioner is connected in-parallel with the AC line, and constantly injects currents that precisely correspond to the harmonic components drawn by the load. The result is that the current supplied by the power source remains sinusoidal.



$$I_{load} = I_{fundamental} + I_{harmonic}$$
$$I_{conditioner} = I_{harmonic}$$
$$I_{load} = I_{source} + I_{conditioner}$$

Fig. 04 - Active harmonic compensation principle

The normal power source provides the fundamental current, and the harmonic currents required by the load are supplied by the active harmonic conditioner (AHC).

The entire low-frequency harmonic spectrum (**H2 to H25**) is covered.

If the harmonic currents drawn by the load are greater than the rating of the active conditioner, the conditioner automatically limits its output current to its rated one.

Easy to implement, an active conditioner may be installed at any point on a low-voltage AC system to compensate the power drawn by one or several non-linear loads, thus avoiding the circulation of harmonic currents throughout the low-voltage AC system.

recording of real current for non-linear load

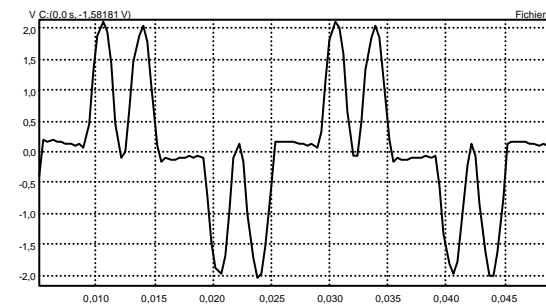

Fig. 05 - I_{load} = load current (Graetz bridge), $I_{rms} = 82\text{ A}$ THDI = 41%

5. parallel active harmonic conditioner: system description

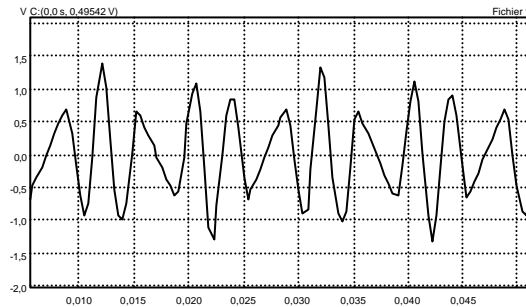

Fig. 06 - I conditioner, I rms = 30 A

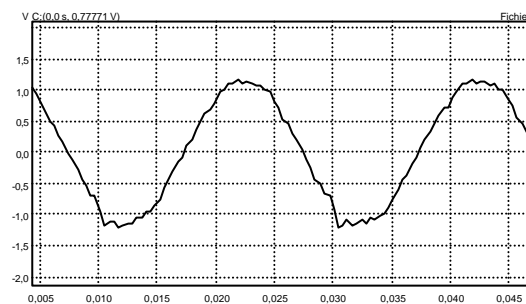

Fig. 07 - I source = source current, I rms = 75 A, THDI = 3.6%

detailed description

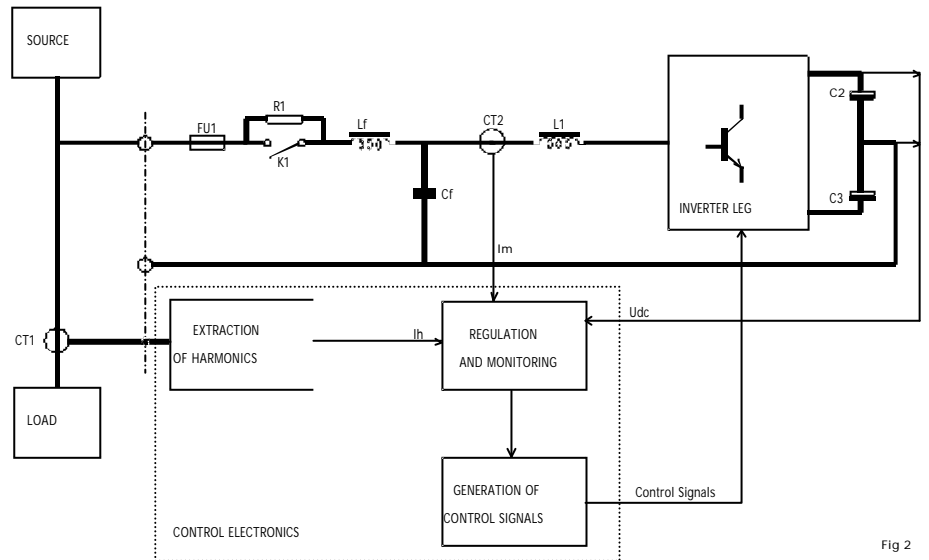

Fig. 08 - Active conditioner single-line diagram

The active harmonic conditioner is made up of the following elements:

- FU1: ultra fast protection fuse;
- R1 and contactor K1: precharge system for chemical capacitors C2 & C3;
- Lf & Cf: filter intended to attenuate the effects of chopping;
- L1, DC/ac converter, C2 and C3: PWM inverter leg;
- CT2: sensors for inverter currents;
- control electronics;
- CT1: external sensor for current drawn by the load.

5. parallel active harmonic conditioner: system description

(cont.)

The converter comprises a three phase IGBT current inverter leg that chops at an average switching frequency of 16 kHz, chemical capacitor C2 and C3 providing back up power. The conditioner draws from the power source the active power required for its operation.

The control electronics comprise:

- an harmonic-extraction module which generates a regulation set point proportional to the harmonic components of the load current;
- a module that regulates inverter currents and the DC voltage;
- a monitoring module which ensures filter protection in the event of overload or an internal fault;
- a control module which generates the control signals necessary for inverter operation.

To enhance the compensation capacity at a given point in the installation, it is possible to connect active conditioners in parallel.

points of connection of the active conditioner

The active conditioner may be installed at different points on AC distribution systems:

- close to the loads generating high level of harmonics to ensure local compensation of harmonic currents;
- partial compensation of harmonic currents;
- centrally, at the PCC level, for global compensation of harmonic currents.

Ideally, compensation of harmonics should take place at their point of origin.

A number of cost and technical criteria are used to make the best selection.

Mains advantages of the local compensation:

- avoid dissemination of the harmonic currents in the electrical installation;
- reduce Joule-effect losses in the cables, and load on the main transformer;
- reduces size of the cables required in new installations;
- means installation can meet applicable harmonic standards.

6. case study : ELF AQUITAINE (cont)

description of the l'installation

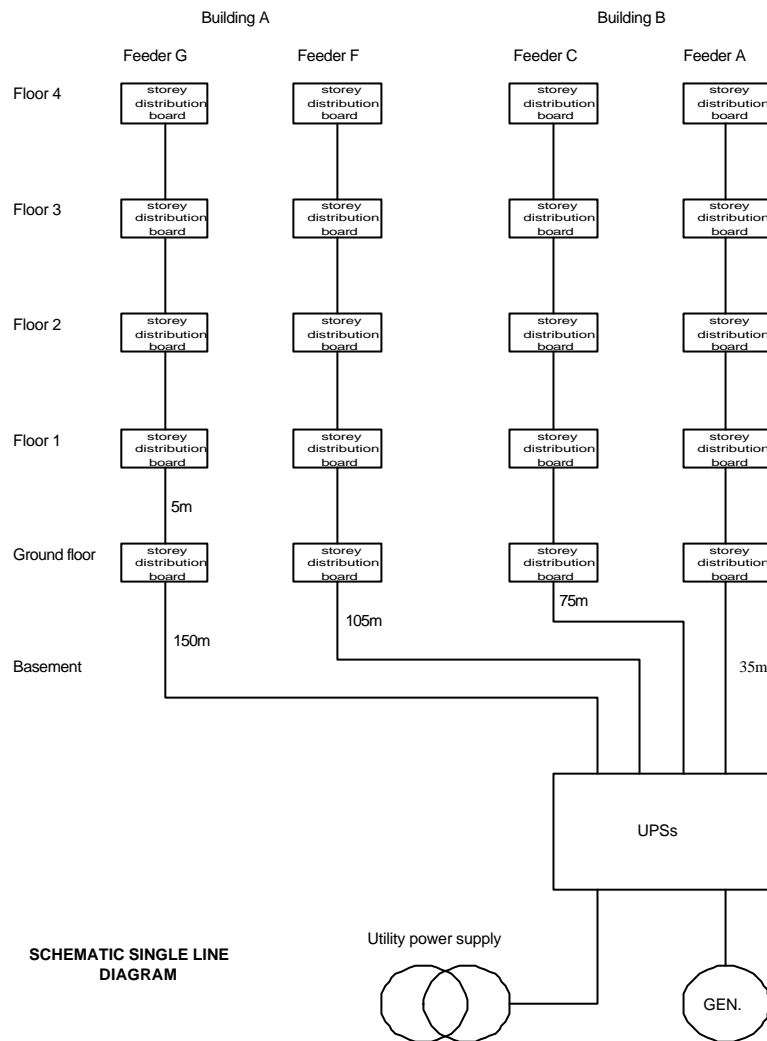

Fig. 09 - Schematic single line diagram of the installation

A centralised UPS system supplies two buildings, each one of 4 floors. This UPS system as a dual feed supply, either the utility power or a generator set. The distance from the UPS system to the building ranges from 35 m to 150 m.

In each building, distribution is provided through two main feeders; on each floor, a storey distribution board supplies all the information technology equipment: PC, workstations servers.

AC distribution system is 4 wires (three phases + neutral), with the neutral conductor sized at 50% of the phase conductor.

6. case study (cont.)

problems experienced by Elf and site audit

Elf experienced several type of disturbances:

- functional problems in computers;
- breakdown and failure of very sensitive IT equipment, as well as damages;
- temperature rise in the neutral conductor, and excessive heat losses;
- downstream the storey distribution board, voltage distortion non compatible with the standard compatibility levels, and the computer specifications.

Most of the loads is single phase and non-linear. At the basement level, measures demonstrate a total current harmonic distortion of 86%, and a current harmonic distortion of 69% for the 3rd order.

Then, the circulation of these harmonic currents in the long cables generates a high voltage distortion at the end of the cables, where the critical IT equipment are connected. At the point of use, the voltage distortion is double versus the one at the UPS output: 8.3% vs 4.2%. When operating on the generator set and on the static by-pass of the UPS system, during maintenance or test, voltage distortion up to 15% was noticed.

Also, the neutral current is 140% of the phase current, creating over temperature in the neutral conductor, and neutral to earth voltage as high as 8 V.

The here after table summarises the voltage measures focused on the feeders F and G:

	THDU phase / neutral	voltage neutral / earth
UPS output	4,2%	0 V
feeder G - 4th floor	8%	8,3 V
feeder G - comp. suite	8,3%	-
feeder F - 4th floor	5,7%	4 V
feeder C - 4th floor	6%	4,4 V

The following table gives the detailed measures of feeder G, at the basement level:

total I rms	66 A
crest factor	2,3
THDI	86%
power factor	0,72
I harmonic rms	42 A
THDU	7,7%
neutral / earth voltage	7,9 V
I neutral rms	108 A

6. case study (cont.)

analyse of the solutions

Of course, the solution implemented has to eliminate the disturbances experienced by Elf, but also must guaranty a voltage distortion lower than 5% at the point of use, i.e. at the input of the computer equipment.

Several solutions were proposed and compared by the consultant who carried out the site audit. They are listed here after:

- installation of double wound transformer on each feeder;
- renewal of the overall distribution, changing also the earthing system;
- increase of the size of the neutral conductor;
- installation of active harmonic conditioner(s) at the basement level of each feeder.

The advantages and disadvantages of each solutions were evaluated carefully, both on the economical and technical viewpoints. The analyse is summarised in the following table:

	advantages	disadvantages
transformer	<ul style="list-style-type: none"> ■ elimination of voltage drops due to harmonic current circulation; ■ elimination of third harmonic. 	<ul style="list-style-type: none"> high price; ■ derating of transformer; ■ influence of inrush current on UPS.
renewal	<ul style="list-style-type: none"> ■ ease of implementation. 	<ul style="list-style-type: none"> ■ new earthing system not recommended; ■ difficulty to master the circulating currents in the AC system; ■ no reduction of the voltage distortion.
increase of neutral conductor size	<ul style="list-style-type: none"> ■ no change of the earthing system and mastering of circulating neutral current. 	<ul style="list-style-type: none"> ■ no reduction of the voltage distortion; ■ slight reduction of the voltage drop in the neutral conductor; ■ a lot of cabling works.
active harmonic conditioner	<ul style="list-style-type: none"> ■ competitive price; ■ reduction of the voltage distortion; ■ reduction of the neutral current; ■ significant decrease of the rms current. 	<ul style="list-style-type: none"> ■ need to install 2 conditioners on the same feeder (F & G).

The active harmonic conditioner solution was selected as it was the most competitive, and the only one to 100% meet the customer requirements.

final solution

To get the best benefit for the customer, one active conditioner will be connected to each feeder, at the basement level.

For feeders F & G, whose distance from UPS system is very long, one additional conditioner will be installed at the 2nd floor level. Then, harmonic distortion at 4th floor will be as low as possible.

6. case study (cont.)

site results

This section describes the waveform and the characteristics of the power of feeder G after connection of one 30 A active harmonic conditioner at the basement level. This is the first step of the implementation of the solution.

The measures and results presented here after gives a good idea of the improvement thanks to the active harmonic conditioner.

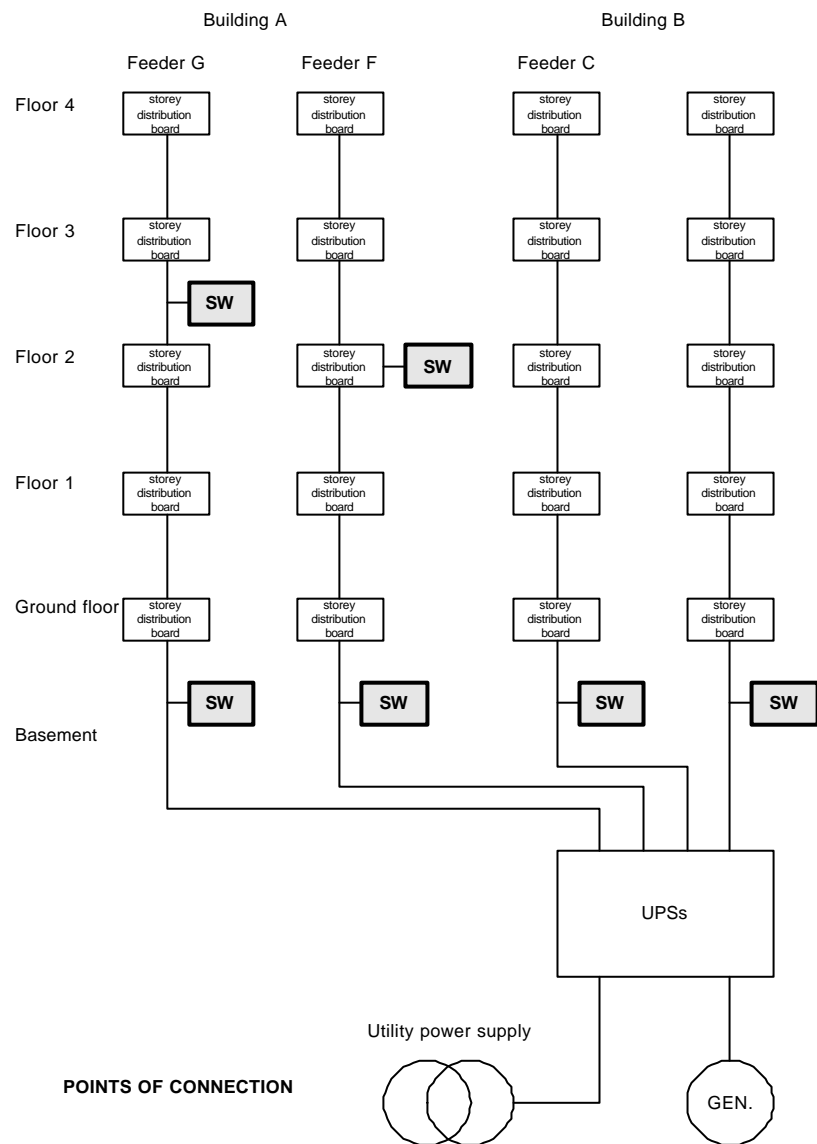

Fig. 10 - Points of connection of the active conditioners

6. case study (cont.)

Voltage waveform at 4th floor

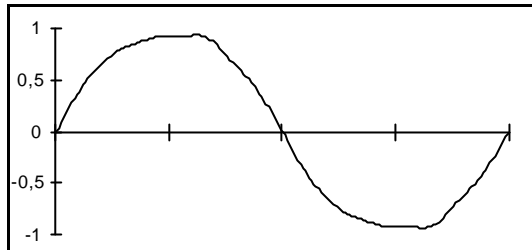

Fig. 11 - Voltage waveform without active conditioner

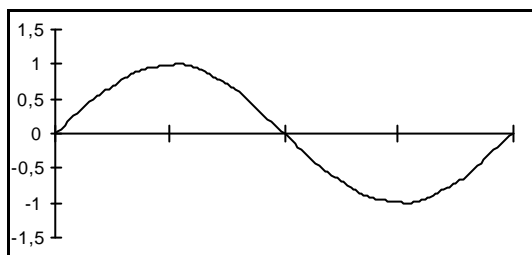

Fig. 12 - Voltage waveform with active conditioner

Conclusion:

The total voltage harmonic distortion is reduced from 7.7% to 4.6%, and the neutral to earth voltage from 7.9 V to 4.4 V.

Current waveform

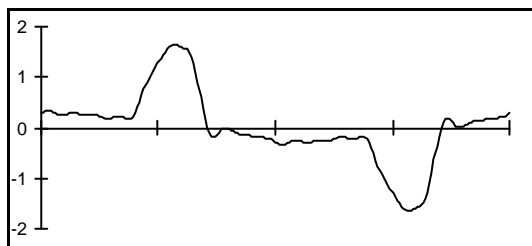

Fig. 13 - Line (load) current waveform without active conditioner

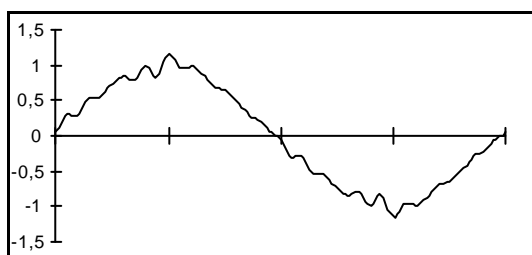

Fig. 14 - Line (source) current waveform with active conditioner

6. case study (cont.)

Conclusion:

The benefit of the active conditioner is clearly demonstrated on the current.

- reduction of 29% of the rms current (from 66 to 47 A);
- crest factor decreased to 1.92 after compensation (vs 2.3);
- improvement of the power factor from 0.72 to 0.92.

harmonic spectrum

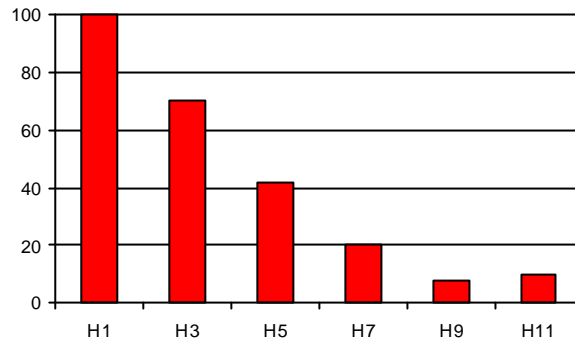

Fig. 15 - Line (load) current spectrum (% of H1) without active conditioner

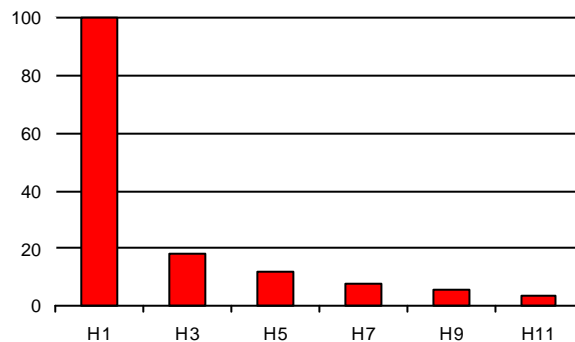

Fig. 16 - Line (source) current spectrum (% of H1) with active conditioner

Conclusion:

The graphs show the impact of the SineWave active conditioner on the harmonic currents. Due to the high harmonic current, the active conditioner operates in limitation mode and compensates partly for the harmonic currents.

- THDI attenuation of 3: 86% down to 28%;
- reduction of 65% of the neutral current: 108 A down to 38 A;
- reduction by 70% of the harmonic rms current: 42 A down to 13 A.

7.comparison between active harmonic conditioner and tuned passive filter

	passive filter	active harmonic conditioner
harmonic-current control	requires a filter for each frequency (bulky)	simultaneously monitors several frequencies
influence of a frequency variation	reduced effectiveness	no effect
influence of a modification in the impedance	risk of resonance	no effect
influence of an increase in current	risk of overload and damage	no risk of overload, but less effective
added equipment (load)	in certain cases, requires modifications to the filter	no problem if $I_{conditioner} > I_{load_harmonics}$
harmonic control by order	very difficult	possible via parameters
modification in the fundamental frequency	cannot be modified	possible via reconfiguration
dimensions	large	small
weight	high	low

8. conclusion

A 30 Amp "shunt topology" active harmonic conditioner was successfully developed, and is being marketed.

All the installations equipped with the SineWave active harmonic conditioner demonstrate excellent performances in a wide range of applications. Regarding computer type loads, the presented case study is a clear demonstration of the high level of harmonic current compensation that the conditioner can achieve. As a consequence of the compensation of the 3rd harmonic current, the active conditioner also reduces the neutral (harmonic) current.

These results gives very good reasons to expect in a very short time the development of active harmonic conditioner to compensate harmonic distortion in the commercial applications, but also in the industrial sector.

Annex 1

references

- G W Massey, "Power Distribution System Design for Operation Under Non sinusoidal Load Conditions", IEEE Trans. Ind.Applic., vol.31 n° 3, may/june 1995.
- S Fukuda and T Endoh, "Control Method for a Combined Active Filter System Employing a Current source Converter", IEEE Trans. Ind. Applic., vol. 31 n°3, may/june 1995.
- T Deflandre, C Courty, C Greiveldinger, EDF, "Impact des Harmoniques sur les Réseaux Publics Français", PPRD, 1995.
- T Key and J S Lai, "Costs and benefits of Harmonic Current reduction for Switch-mode Power Supplies in a Commercial Building", sept. 1995.
- W Russell, "Hardening data Lines to IEC 1000-4-2, Compliance European Edition", jan./feb. 1996.
- J Moravek, "Benefits of Using a harmonic monitoring Program", EC&M, sept. 1994.
- L Lachaume and JM Vialars, "Electric Energy Metering in Presence of Harmonics", EDF study, nov. 1994.
- R Waggoner, "Beware of Single-phase Harmonic interactions", EC&M, june 1994.
- P N Enjeti, W Shiren, P Packebush, I Pitel, "Analysis and Design of a new active Power Filter to Cancel Neutral Current harmonics in Three-phase Four-wire Electric Distribution Systems", IEE Trans. Ind. Applic., vol. 30 n°6, dec. 1994.
- S Bernard, G Trochain, "A New High Performance Active Harmonic Conditioner Based on the Current Injection Mode", Power Quality 95, nov. 1995.
- M Mc Granaghan, L Tang, S Beranrd, S Papoz, "Evaluation of Active Filter Design and performance Using a Detailed EMTP Model", PQA 95, may 1995.
- H Akagi, "New Trends in Active Filters", EPE 95, sept. 1995.
- T Key, JS Lai, "Comparison of Standards and Power Supply Design Options for Limiting Harmonic Distortion in Power Systems", IEEE Trans. Ind. Applic., vol 29 n°4, jul./aug. 1993.

MGE UPS SYSTEMS

140, avenue Jean Kuntzmann
Zirst Montbonnot Saint Martin
38334 SAINT ISMIER Cedex
France
Tel : 33 (0) 4 76 18 30 00
www.mgeups.com

MGE0128UKI

As standards, specifications and designs change from time to time, please ask confirmation of the information given in this publication.

Product names mentioned herein may be trademarks and/or registered trademarks of their respective companies.

Published by: MGE UPS SYSTEMS – 01/2000
Designed by: AMEG

